

LAMPHEAD UNIT

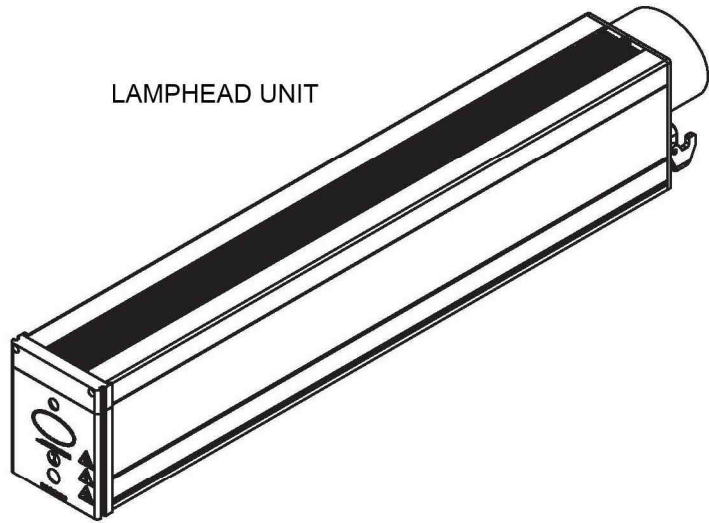

EMWI
EMWI GROUP

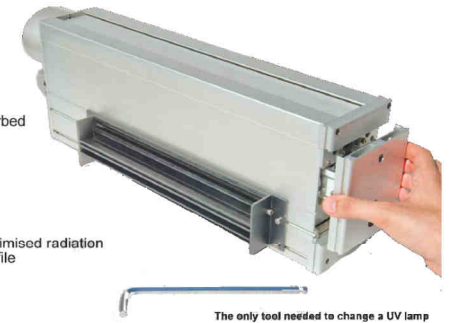
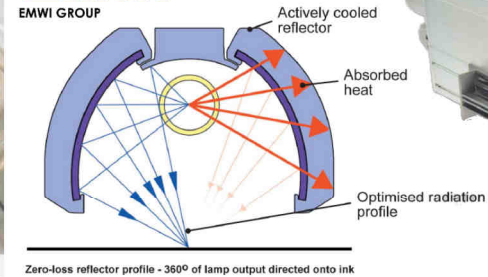

(1:5)

POWER AND CONTROL CABINET

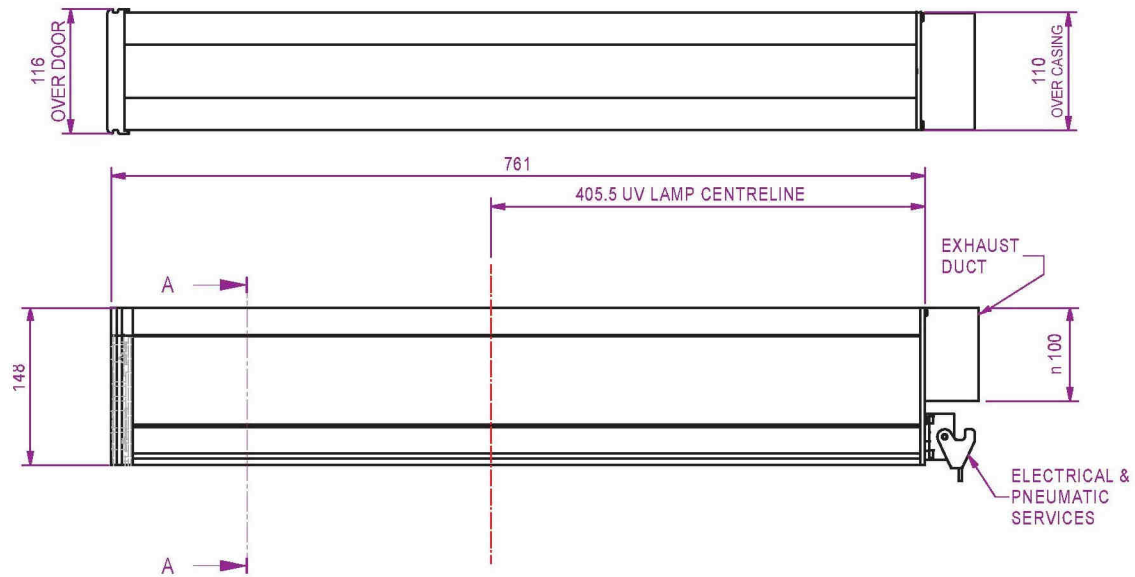
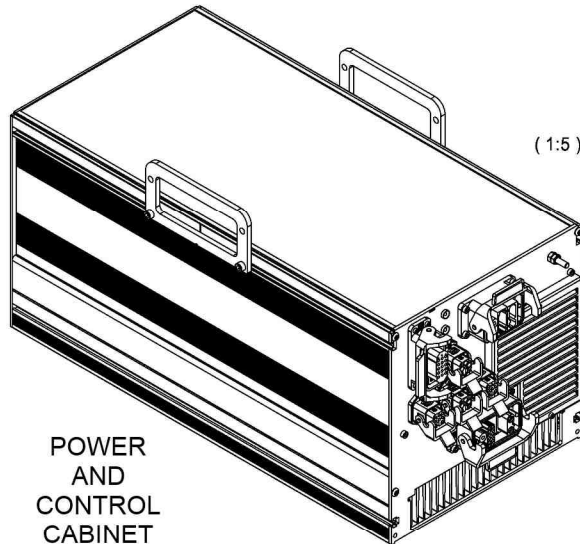

Components of one lamphead UV curing system (second lamphead as option).
Installation: On Emwi Belt Conveyors and/or on customer machine (technical inspection needed)

DIM. UNITS: mm
UNSPECIFIED TOL.
LINEAR: ±0.5

TITLE:

55 CM DRYER

SCALE



A3

SHT

1/1

ASSEMBLY NUMBER

REV

A